



Owner's Manual

Arm-type Fully Automatic Digital Blood Pressure Monitor OBP201BT



Please read the instruction manual carefully before using the product

WARRANTY CARD	
Model No.:.....	Lot No.:.....
Invoice No.:.....	Date of Purchase:.....
Purchased By:.....	Contact No.:.....
Address:.....	
Dealer's Name:.....	
Dealer's Sign & Stamp	

Warranty

Passim Lifesciences Ltd. warrants this unit against defects in materials and workmanship for 12 months from the date of purchase. During the warranty period, any defective parts will be repaired or replaced free of charge, excluding consumable components which are not covered once used.

Warranty is void if:

- The device is misused or not maintained per this manual.
- Unauthorized repairs or modifications are made.
- Operated in corrosive or harmful environments.
- The warranty card is not fully completed and presented upon claim.

Symbols

- Medical Device
- Refer Instructions Manual
- No Trash
- Manufactured By
- Lot No.
- Keep Away From Sunlight
- Serial No.
- Do not use if Package damaged
- Warning/Caution
- Must not be exposed in rain or excessive moisture
- Manufacturing Date

Contact Information

Manufactured By:
Passim Lifesciences Ltd., Plot No. 45,
Industrial Area, Phase 2, Panchkula,
Haryana 134113, India

Mfg. Lic. No.: MFG/MD/2022/000615
WPC ETA Reg. No.: ETA-SD-20250807416

For complaints or suggestions :
Customer Care No.: 1800 309 3009
(Timing: 9am - 7pm, Mon-Sat.)
Email ID: customercare@droidin.in
Website: www.droidin.in

* Terms & Conditions Apply
IM/OBP/102-00

Blood Pressure Monitor OBP201BT with Bluetooth

Thank you for purchasing the OBP201BT Blood Pressure Monitoring Device. The unit has been constructed using reliable circuitry and durable materials. Used properly, this unit will provide years of satisfactory use.

This device is intended for non-invasive measuring an adult individual's systolic, diastolic blood pressure and heart rate using the oscillometric method. The device is not intended for use on infants and children. The device is designed for home or clinical use. All functions can be used safely and values can be read out in LCD DISPLAY. Measurement position is on adult upper arm only.

Please read this manual thoroughly before using the unit. Please retain this manual for future reference. For specific information about your blood pressure, please CONSULT YOUR DOCTOR.

To avoid risk and damage follow all warning precautions. Operate unit only as intended. Read all instructions prior to use.

Important Testing Guidelines

1. Avoid eating, exercising, and bathing for 30 minutes prior to testing.
2. Sit in a calm environment for at least 5 minutes prior to testing.
3. Do not stand while testing. Sit in a relaxed position while keeping your arm level with your heart.
4. Avoid speaking or moving body parts while testing.
5. While testing, avoid strong electromagnetic interference such as microwave ovens and cell phones.
6. Wait 3 minutes or longer before re-testing.
7. Try to measure your blood pressure at the same time each day for consistency.
8. Test comparisons should only be made when monitor is used on the same arm, in the same position, and at the same time of day.
9. This blood pressure monitor is not recommended for people with severe arrhythmia.
10. Do not use this blood pressure monitor if the device is damaged.

Unit Operation

How to Connect Your Dr. Odin BP Monitor

Step 1: Download the App

First, you'll need to download the official Dr. Odin app. You can find it by searching for "Dr. Odin" on the Google Play Store for Android devices or the Apple App Store for iOS devices.

Step 2: Enable Bluetooth

Once the app is installed, open it on your device. The app requires connection signal to function, so make sure it's enabled in your smartphone's Settings menu. This allows the app and the BP monitor to communicate with each other.

Step 3: Log In or Create an Account

You'll be prompted to either create a new user account or log in with an existing one. Follow the on-screen instructions to proceed.

Step 4: Pair Your Device

On the app's home screen, navigate to the "Connect Your Devices" section and select BP Monitor. Next, start your Dr. Odin BP machine to begin a blood pressure reading. The app will automatically detect the device. Then tap on device to connect it with you app.

Step 5: Sync Your Data

After the BP monitor completes the measurement, the results will be automatically reflected on the app via connection. The app will then save this data to your memory for future reference and tracking.

Important Note: To ensure a successful data transfer, keep the app open and active on your phone until the measurement is complete and the results have appeared.



Troubleshooting



If you encounter any issues with the connection, try the following steps:

1. Restart the app.
2. Re-connect the device by repeating the pairing process.



Remember, even if communication fails, you can always view your measurement data directly on the BP monitor's display.

Safety Notice

 Caution	
Individuals with serious circulation problems may experience discomfort. Consult your physician prior to use.	
Contact your physician if test results regularly indicate abnormal readings. Do not attempt to self-treat these symptoms without consulting your physician first.	
Product is designed for its intended use only. Do not misuse in any way.	
Product is not intended for infants or individuals who cannot express their intentions.	
Do not disassemble or attempt to repair.	
Do not use cell phones and other devices, which generate strong electrical or electromagnetic fields, near the device, as they may cause incorrect readings and interference or become interference source to the device.	
Only use a recommended AC adaptor double-insulated complying with EN 60601-1 and EN 60601-1-2 (see page 6).	

 Battery Precautions	
This product contains lithium battery, do not discard.	
Replace batteries when Low Battery Indicator "  " appears on screen.	
Please charge the lithium battery every once in a while to ensure the normal power.	
Dispose batteries properly; observe local laws and regulations.	
Users are not allowed to replace the lithium battery by themselves. If it is confirmed that the lithium battery is faulty, please do not repair it by yourself. Please contact the system in timeManufacturer or dealer.	

Safety Notice

20. The system might produce incorrect readings if stored or used outside the manufacturer's specified temperature and humidity ranges.
21. Do not use the device near strong electrical or electromagnetic fields generated by cell phones or other devices, they may cause incorrect readings and interference or become interference source to the device. Do not use the device during patient transport outside healthcare facility for interference source existing as well.
22. This product contains lithium battery, do not discard.
23. Replace batteries when Low Battery Indicator "  " appears on screen. Replace both batteries at the same time.
24. Please charge the lithium battery every once in a while to ensure the normal power.
25. Dispose batteries properly; observe local laws and regulations.
26. Users are not allowed to replace the lithium battery by themselves. If it is confirmed that the lithium battery is faulty, please do not repair it by yourself. Please contact the system in timeManufacturer or dealer.
27. Dispose batteries properly; observe local laws and regulations.
28. Only use a recommended AC adaptor double-insulated complying with EN 60601-1 and EN 60601-1-2. An unauthorized adapter may cause fire and electric shock.
29.  Advising operator that Instruction manual/ Booklet must be consulted.

Safety Notice

Important Instructions Before Use

1. Do not confuse self-monitoring with self-diagnosis. Blood pressure measurements should only be interpreted by a health professional who is familiar with your medical history.
2. Contact your physician if test results regularly indicate abnormal readings.
3. If you are taking medication, consult with your physician to determine the most appropriate time to measure your blood pressure. NEVER change a prescribed medication without first consulting with your physician.
4. Individuals with serious circulation problems may experience discomfort. Consult your physician prior to use.
5. For persons with irregular or unstable circulation resulting from diabetes, liver disease, arteriosclerosis or other medical conditions, there may be variations in blood pressure values measured at the wrist versus at the upper arm. Monitoring the trends in your blood pressure taken at either the arm or the wrist is nevertheless useful and important.
6. People suffering from vascular constriction, liver disorders or diabetes, people with cardiac pacemakers or a weak pulse, and women who are pregnant should consult their physician before measuring their blood pressure themselves. Different values may be obtained due to their condition.
7. People suffering from arrhythmias such as atrial or ventricular premature beats or atrial fibrillation only use this blood pressure monitor in consultation with your doctor. In certain cases oscillometric measurement method can produce incorrect readings.
8. Too frequent measurements can cause injury to the patient due to blood flow interference.
9. The cuff should not be applied over a wound as this can cause further injury.
10. **DO NOT** attach the cuff to a limb being used for IV infusions or any other intravascular access, therapy or an arterio-venous (A-V) shunt. The cuff inflation can temporarily block blood flow, potentially causing harm to the patient.
11. The cuff should not be placed on the arm on the side of a mastectomy. In the case of a double mastectomy use the side of the least dominant arm.
12. Pressurization of the cuff can temporarily cause loss of function of simultaneously used monitoring equipment on the same limb.
13. A compressed or kinked connection hose may cause continuous cuff pressure resulting in blood flow interference and potentially harmful injury to the patient.
14. Check that operation of the unit does not result in prolonged impairment of the circulation of the patient.
15. Product is designed for its intended use only. Do not misuse in any way.
16. Product is not intended for infants or individuals who cannot express their intentions.
17. Prolonged over-inflation of the bladder may cause ecchymoma of your arm.
18. Do not disassemble the unit or arm cuff. Do not attempt to repair.
19. Use only the approved arm cuff for this unit. Use of other arm cuffs may result in incorrect measurement results.

Unit Illustration

Monitor Unit

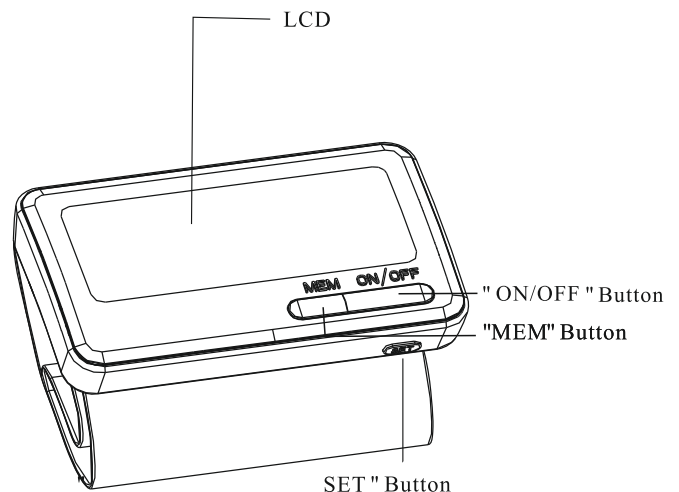

Unit Illustration

Display

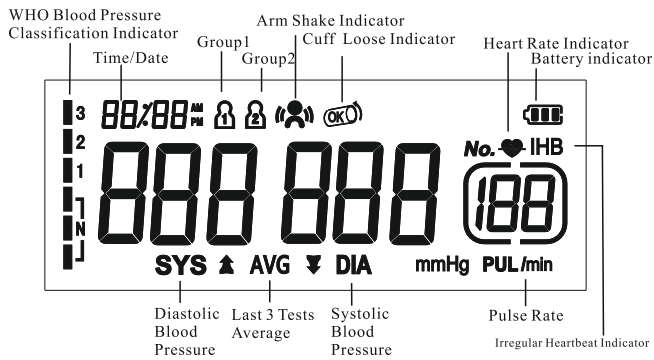

Unit Illustration

Contents

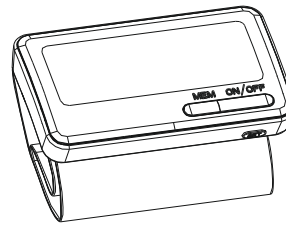

1. Monitor Unit

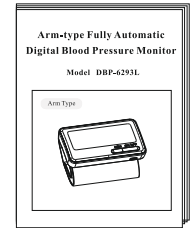

2. Owner's Manual

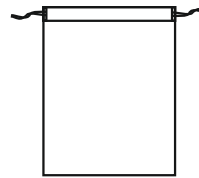

3. Storage Bag



4. USB Cable

Quick Start

1. Open the packing box and take out the device. (See Figure A)

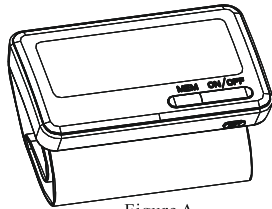

Figure A

2. Remove thick clothing from the arm area.
3. Rest for several minutes prior to testing. Sit down in a quiet place, preferably at a desk or table, with your arm resting on a firm surface and your feet flat on the floor. (See Figure B)



Figure B

4. Apply cuff to your left arm and keep level with your heart. Bottom of cuff should be placed approximately 1-2cm (0.4-0.8") above elbow joint. (See Figures C&D)

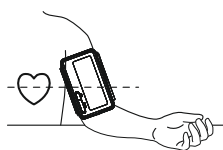

Figure C

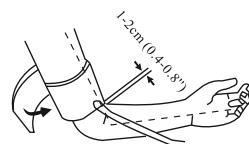

Figure D

5. Press "START/STOP" Button to start testing.

Unit Operation

Lithium Battery Charging

The device has a built-in lithium battery that must be recharged using a specific power adapter. When low battery indicator icon " " appears on the screen Please connect the power adapter to charge. When charging, the screen will be displayed in a cycle from " " to " ". Insert the adapter connector into the adapter interface, then insert the adapter into the socket, and then connect the adapter to the cable end Insert the adapter interface on the device and press the on/off button to measure normally. (if this model has been packed)When you plug in the adapter, the screen power display changes, indicating that you are using the adapter for power. When a device is connected to an adapter, the power adapter is part of the entire device.

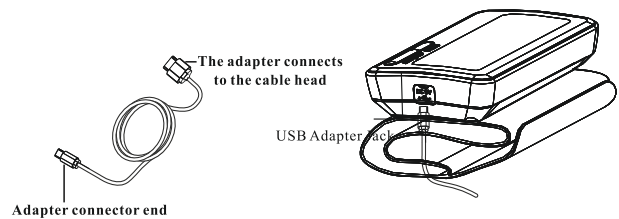

Note: Power supply is specified as part of ME EQUIPMENT. Do not use other non-standard adapters. Use UE05LV4-050100SPA or UE05LU4-050100SPA adapters.

Unit Operation

System Settings

With power off, press "SET" button to activate System Settings. The Memory Group icon flashes.

1. Select Memory Group

While in the System Setting mode, you may accumulate test results into 2 different groups. This allows multiple users to save individual test results (up to 150 memories per group.) Press "MEM" button to choose a group setting. Test results will automatically store in each selected group.

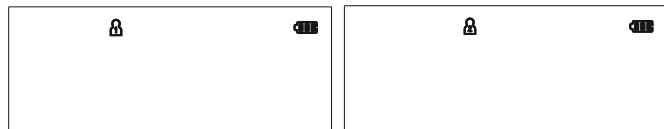

2. Time/Date setting

Press "SET" button again to set the Time/Date mode. Set the year first by adjusting the "MEM" button.

Press "SET" button again to confirm current month. Continue setting the dat, hour and minute in the same way. Every time the "SET" button is pressed, it will lock in your selection and continue in succession (month,day,hour, minute,12/24 hours)

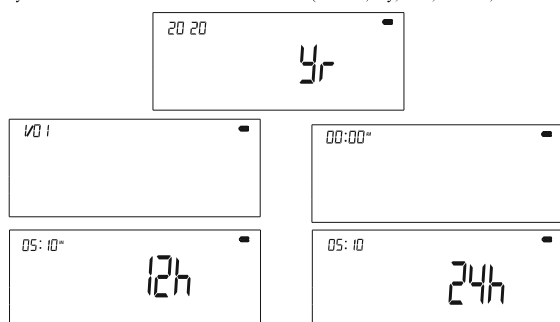

Unit Operation

3. Time Format setting

Press "SET" button again to set the time format setting mode. Set the time format by adjusting the "MEM" button. EU means European Time US means U.S Time

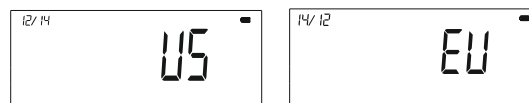

4. Saved Settings

While in any setting mode, press "ON/OFF" button to turn the unit off. All information will be saved.

Note: If unit is left on and not in use for 3 minutes, it will automatically save all information and shut off.

Unit Operation

Applying the Arm Cuff

1. Pick up the sphygmomanometer, open the arm band, put the sphygmomanometer and arm band on the arm, to firm air leakage is appropriate;



2. With sticky nylon section facing outward, insert end of cuff underneath metal ring of cuff.

3. Fasten cuff about 1-2cm (0.4-0.8") above the elbow joint. For best results apply cuff to bare arm and keep level with heart while testing.

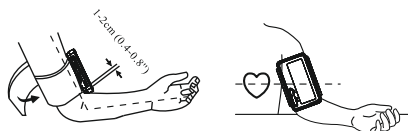

Note: Do not insert air plug into opening located on right side of monitor unit. This opening is designed for an optional power supply only.

Unit Operation

Testing

1. Power On

Press and hold "START/STOP" button to turn the unit on. The LCD screen will appear for one second as unit performs a quick diagnosis. A long tone will indicate when unit is ready for testing.

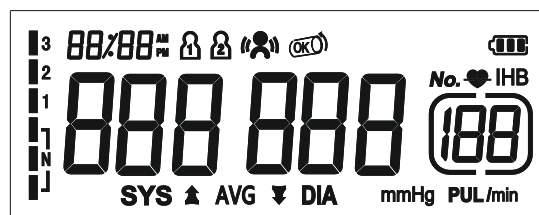

Note: Unit will not function if residual air from previous testing is present in cuff. The LCD will flash "▼" until pressure is stabilized.

2. Testing

After cuff inflation, air will slowly rise as indicated by the corresponding cuff pressure value. A flashing "♥" will appear simultaneously on screen signaling heart beat detection.

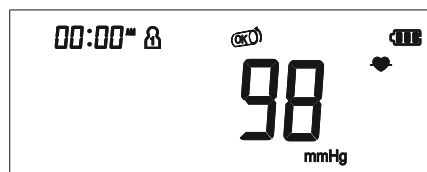

Note: Keep relaxed during testing. Avoid speaking or moving body parts.

Unit Operation

3. Result Display

Four short beeps sound when testing is complete. The screen will display measurements for systolic and diastolic blood pressure. An indicator representing the current measurement will appear next to the corresponding WHO Classification.



Note: Refer to Page 23~24 for detail WHO Blood Pressure Classification Information.

Irregular Heartbeat Indicator

If the monitor detects an irregular heart rhythm two or more times during the measuring process, the Irregular Heartbeat Symbol "IHB" appears on screen along with measurement results. Irregular heartbeat rhythm is defined as rhythm that is either 25% slower or faster than the average rhythm detected while measuring systolic blood pressure and diastolic blood pressure. Consult your physician if the Irregular Heartbeat Symbol "IHB" frequently appears with your test results.

Power Off

The "START/STOP" button can be pressed to turn off the unit in any mode. The unit can turn off the power itself about 3 minutes no operation in any mode.

Safety Precaution: If pressure in arm cuff becomes too extreme while testing, press the "START/STOP" button to turn power off. The cuff pressure will rapidly dissipate once the unit is off.

Unit Operation

Last 3 Tests Average

With power off, press the "MEM" button to activate screen display. After the unit performs a self-diagnosis, the screen will display the average test results from the last 3 readings of the last group used. The "AVG" symbol will appear along with the corresponding WHO Blood Pressure Indicator. The Memory Check mode can be accessed by pressing "MEM" button. To check the average results from other groups, select the desired group first prior to activating "SET" button in the off position. (See "Select Memory Group" on Page 12)

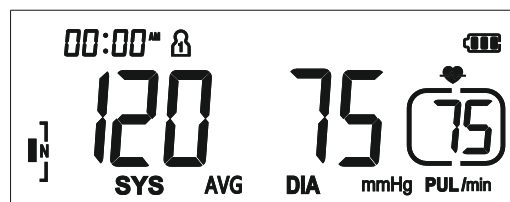

Memory Check

You may check past test results by using the "MEM" button. The most recent test result and oldest test result in memory can be viewed by pressing and holding the "MEM" button. Upon activating test results, you can press the "MEM" button to scroll through all test results stored in memory.

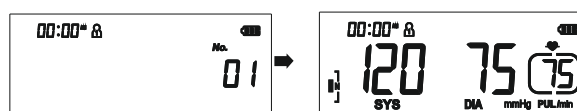

Arm Shake Indicator

If there is arm movement during the measurement, the "AS" icon may flash. Indicates that the measurement results may be inaccurate, and the situation will be recorded at the end of the measurement as a reminder.

Cuff loose Indicator

When starting the measurement, "OK" will be displayed when the cuff is properly wound.

When the cuff is too loose, "LO" will be displayed. At this time, please wear the cuff correctly and start measuring again.

Unit Operation

Memory Deletion

Memory for a selected group may be deleted while in Memory Check mode. Press and hold the "SET" button for approximately 3 seconds to delete all memory records from the selected group. The monitor will beep indicating successful deletion and then transfer into testing mode. Press the "START/STOP" button to turn the unit off.

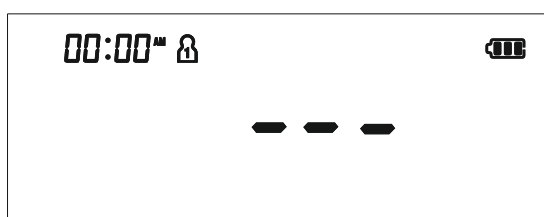

Note: Memory cannot be recovered once it has been deleted.

Low Battery Indicator

Four short warning beeps sound when battery life is depleting and unable to inflate cuff for testing. The "BAT" icon appears simultaneously for approximately 5 seconds prior to shutting off. Replace batteries at this time. No memory loss will occur throughout this process.



Unit Operation

Static Pressure Measurement

In the power down state, press and hold the "START/STOP" button, and then install the batteries. Until the LCD screen is full, release the "START/STOP" button.

When the LCD screen displays the double zero, the blood pressure meter is in static state.

Software version is displayed: 10 is a software version in the figure.

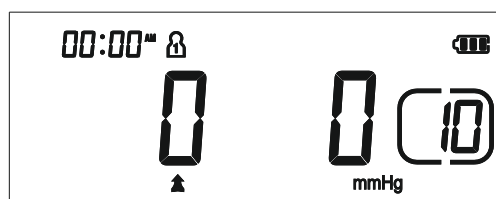

Note: Only Service personnel permitted to access to this mode, the mode unavailable in normal use.

Bluetooth requirements

The monitor requires a device with:

- . Bluetooth 4.0 or later
- . Android 5.0 or later
- . IOS 9.0 or later

And works with:

- . iPhone
- . Android Phones

Blood Pressure Information

Health Reminder

Hypertension is a dangerous disease that can affect the quality of life. It can lead to a lot of problems including heart failure, kidney failure, and cerebral hemorrhaging. By maintaining a healthy lifestyle and visiting your physician on a regular basis, hypertension and relative diseases are much easier to control when diagnosed in their early stages.

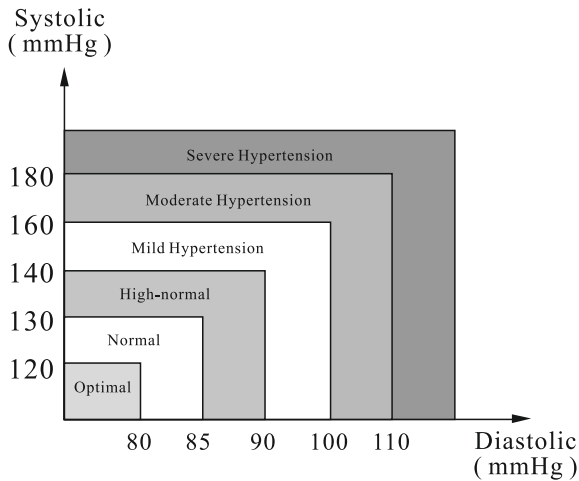

Note: Do not be alarmed if an abnormal reading occurs. A better indication of an individual's blood pressure occurs after 2-3 readings are taken at the same time each day over an extended period of time. Consult your physician if test results remain abnormal.

Unit Operation

Troubleshooting

Abnormal phenomenon	Cause analysis	Processing method
Abnormal sphygmomanometer	The armband is tied too tight or too loose, Or the arm strap is tied incorrectly;	Roll the armband correctly
	Move the arm during measurement or Electronic sphygmomanometer	Stay quiet, keep your arm steady, and do not move the monitor
	Speaking, nervous or emotional during measurement	Instead of talking, take deep breaths to calm your mood and relax your body
	Incorrect measurement posture	Adjust posture, see "Blood pressure gauge Wearing"
	There is interference in charging process or improper operation in measuring process	See operation Instructions.

The following table shows the error signs that may occur during measurement, possible causes and handling methods. Please measure again using the correct method

Error display	The cause of the problem	The solution
Er1	Can't detect high and low pressure	Please fasten the cuff before measuring
Er2	Cuff too loose or loose	Please fasten the cuff before measuring
Er3	Severe arm or body movement leads to abnormal reporting errors	Hold the arm or body still and measure again
Er4	The pressure exceeds 300mmHg	Please fasten the cuff before measuring
Er5	The pressure exceeds 15mmHg for 3 minutes	Check whether the cuff is knotted or the vent valve is blocked. If the problem persists, contact the manufacturer
Er6	Blood pressure measurements were out of range	Please tighten and measure again. If you cannot solve the problem, please contact the manufacturer
	Low Battery	Replace the battery or connect the power adapter (if any).

Note: If you cannot solve the abnormal situation by yourself, you can consult the manufacturer or the manufacturer's designated unit by phone. It is forbidden to disassemble and repair without permission. If necessary, professional maintenance personnel can ask the manufacturer for the list of components and circuit schematic diagram.

Blood Pressure Information

Blood Pressure

Blood pressure is the force of blood pushing against the walls of arteries. It is typically measured in millimeters of mercury (mmHg.) Systolic blood pressure is the maximum force exerted against blood vessel walls each time the heart beats. Diastolic blood pressure is the force exerted on blood vessels when the heart is resting between beats.

An individual's blood pressure frequently changes throughout the course of a day. Excitement and tension can cause blood pressure to rise, while drinking alcohol and bathing can lower blood pressure. Certain hormones like adrenaline (which your body releases under stress) can cause blood vessels to constrict, leading to a rise in blood pressure.

If these measuring numbers become too high, it means the heart is working harder than it should.

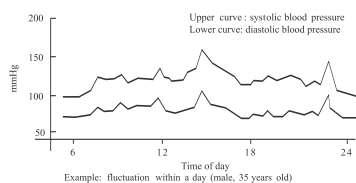

OPERATING PRINCIPLES

Oscillogram method: Also known as pressure oscillation method, this process is to inflate the cuff to block arterial blood flow, and then detect the gas pressure in the cuff during the process of deflating and extract weak pulse waves. The sphygmomanometer is used to measure blood pressure in the process of pressor, so the control algorithm and structure are needed to make the pressure process stable and uniform. The measurement principle is also oscillographic method, which is consistent with the antihypertensive sphygmomanometer. When the measurement results, then open the valve to quickly deflate. The corresponding relationship between the oscillatory wave amplitude and the pressure waveform in the oscillogram method of the booster electronic sphygmomanometer is shown in the figure below.

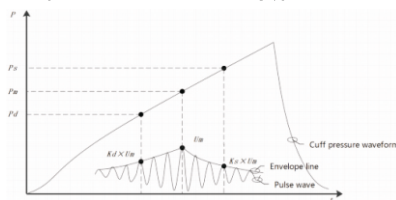

Blood Pressure Information

WHO Blood Pressure Classification Indicator

This is equipped with a classification indicator based on established guidelines from the World Health Organization. The chart below (color coded on monitor unit) indicates test results.

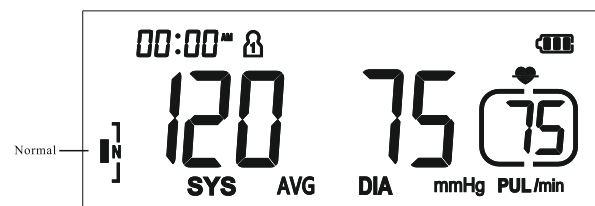
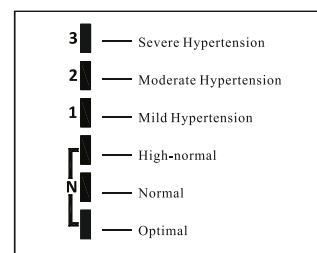

Blood Pressure Classification Indicator

Maintenance

1. Avoid dropping, slamming, or throwing the unit.



2. Avoid extreme temperatures. Do not expose unit directly under sunshine.

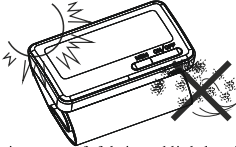

3. When cleaning the unit, use a soft fabric and lightly wipe with mild detergent.

Use a damp cloth to remove dirt and excess detergent.



4. Cuff Cleaning: Do not soak cuff in water! Apply a small amount of rubbing alcohol to a soft cloth to clean cuff's surface. Use a damp cloth (water-based) to wipe clean. Allow cuff to dry naturally at room temperature. The cuff must be cleaned before use between different users.
5. Do not use petrol, thinners or similar solvents.



Maintenance

6. Remove batteries when not in operation for an extended period of time.



7. Do not disassemble product.

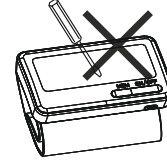

8. It is recommended the performance should be checked every 2 years.
9. Expected service life: Approximately three years at 10 tests per day.
10. No service and maintenance while it is in use and maintenance only be performed by service personnel. Service and maintenance require parts, repair, technical support will be provided.
11. If it is not used for a long time, it is recommended to charge the lithium battery within 3-4 months to ensure that it does not lose power. Users can not replace the lithium battery by themselves. If it is confirmed that the lithium battery is faulty, please do not repair it by yourself. Please contact the manufacturer or dealer in time.
12. If the lithium battery is not charged in time, or the lithium battery is placed for a long time, there may be the situation that the lithium battery is about to run out. In this case, the device cannot be turned on. In this case, the lithium battery should be charged immediately.

The following rules must be observed during use:

1. Prevent lithium batteries from entering water. Do not heat lithium batteries, do not throw lithium batteries into fire.
2. Lithium batteries should not be used for a long time in an environment of more than 60°C.
3. The device can only use lithium batteries specified by the manufacturer.
4. Use the specified AC adapter to charge the device.
5. In order to avoid the normal use of lithium batteries due to self-discharge in the storage process, please charge the lithium batteries every 3-4 months to ensure the normal operation of lithium batteries.

Specifications

Product Description	Arm-type Fully Automatic Blood Pressure Monitor	
Model	OBP201BT	
Display	LCD Digital Display Size: 100mm × 37mm (3.94" × 1.46")	
Measurement Method	Oscillometric Method	
Measurement Range	Systolic Pressure	60mmHg~260mmHg
	Diastolic Pressure	40mmHg~200mmHg
	Pressure	0mmHg~299mmHg
	Pressure	±3mmHg
	Pulse	30 ~ 180 Beats/Minute
	Pulse	±5%
Pressurization	Automatic Pressurization	
Memory	2x150 Memories in Two Groups with Date and Time	
Function	Irregular Heartbeat Detection	
	WHO Classification Indicator	
	Last 3 Tests Average	
	Low Battery Detection	
	Automatic Power-Off	
	Bluetooth	
Power Source	Lithium battery 3.7 V or DC5.0v 1000mA medical external power supply	
Battery Life	Approximately 2 months at 3 tests per day	
Unit Weight	Approx. 123g (4.34 oz.) (excluding battery)	
Unit Dimensions	Approx. 124 x 71.5 x 24.5mm (4.88" x 2.81" x 0.96") (L x W x H)	
Cuff Circumference	Approx. 135 (W) x 485 (L) mm (Medium cuff: Fits arm circumference 22-42cm)	

Specifications

Operating Environment	Temperature	10°C ~ 40°C (50°F ~ 104°F)
	Humidity	15% ~ 93%RH
	Pressure	80kPa~106kPa
Storage Environment	Temperature	-25°C~55°C (-13°F~131°F)
	Humidity	≤93% RH
Transport Environment	Temperature	-25°C~55°C (-13°F~131°F)
	Humidity	≤93% RH
Bluetooth	Version	5.2 BT Signal mode
	Operation frequency	2.4GHz (2400~2483.5MHz)
	Operation distance	≤ 5m
	Transmission power	<20dBm
	Bandwidth	1.0 MHz

Additional Notes

Important Instructions Before Use

1. **WARNING:** Use of this equipment adjacent to or stacked with other equipment should be avoided because it could result in improper operation. If such use is necessary, this equipment and the other equipment should be observed to verify that they are operating normally.
2. **WARNING:** PORTABLE RF communications equipment (including peripherals such as antenna cables and external antennas) should be used no closer than 30 cm (12 inches) to any part of Arm-type Fully Automatic Digital Blood Pressure Monitor, including cables specified by the MANUFACTURER. Otherwise, degradation of the performance of this equipment could result.
3. The software identifier refer to the software evaluation report , and the file code is xxxxxxxxxxxx.
4. **verify manometer pressure accuracy:**
In the power down state, press and hold the " START/STOP" button, and then install the batteries. Until the LCD screen is full, release the " START/STOP" button.
When the LCD screen displays the double zero, the bloodpressure meter is in static state.
At this point, 500ml gas capacity, calibrated standard pressure gauge and manual pressure device can be connected to the sphygmomanometer through the sleeve interface of the sphygmomanometer, and manual pressure can be applied to the effective display range of the sphygmomanometer, and then the difference between the reading of the sphygmomanometer and that of the standard pressure gauge can be compared. This mode can be used to verify manometer pressure accuracy.
5. **Contraindications:**
Product is not intended for infants or individuals who cannot express their intentions.
6. **Intended Use**
The digital blood pressure monitor are reusable for clinical and home use and are non-invasive blood pressure measurement systems designed to measure the systolic and diastolic blood pressure and pulse rate of adolescents and adults individual by using a non-invasive technique, which is a well-known technique in the market called the "oscillometric method".
it can measure the systolic blood pressure, diastolic blood pressure and pulse rated on up-arm, and the device is reusable for clinical or home use.
7. **The patient is the operator:**
the PATIENT is an intended OPERATOR.
the PATIENT Do not carry out other maintenance operations except to replace the battery.
8. **WARNING:**
Do not modify this equipment without authorization of the manufacturer.
9. **ESSENTIAL PERFORMANCE Maintenance advice:**
Pressure calibration will be carried out when this product leaves the factory. Patients can use the method described in the section "Verify Manometer Pressure Accuracy" to verify the accuracy. If the accuracy deviation is large, please contact the manufacturer to recalibration.
10. **Mechanical strength and resistance to heat** The resistance to heat will be retained by device during the EXPECTED SERVICE LIFE of the ME EQUIPMENT.
11. **Do not place the blood pressure monitor and cuff at will.** It will cause asphyxiation if the child swallows or twine around his neck.
12. **The cuff and the case of the blood pressure monitor have been tested for biocompatibility and do not contain allergenic or harmful materials.** Please stop using it if allergy occurs during use.

Additional Notes

13. **Warning:**
Non-professionals do not modify the equipment, otherwise it will make the equipment measurement is not accurate.
14. **Warning:**
Do not expose the equipment for a long time, otherwise it will reduce the performance of the equipment.
15. **Warning:**
This device is not used for children and pets
16. **Clean:**
The equipment can be cleaned by lay operator according to the cleaning procedures in the instructions
17. **Warning:**
Do not use a damaged cuff for blood pressure measurement.
18. **Warning:**
When measuring with the cuff, if the tester feels seriously uncomfortable, press the button of the blood pressure monitor to deflate the cuff, or remove the cuff directly from the arm.
19. **Warning:**
If an unexpected reading occurs, the operator can take several more measurements and consult a doctor.
20. **Warning:**
This equipment is used outside the specified environment, may damage the equipment, and may be inaccurate measurement.
21. **ME equipment not intended for use in conjunction with flammable agents "ME equipment not intended for use in oxygen rich environment".**
22. **Warning:**
The storage device can be used normally two hours after the storage device changes from the highest temperature or lowest temperature to normal temperature.
23. **Warning:**
Instructions provided indicating not to position ME EQUIPMENT to make it difficult to operate the disconnection device.
24. **Warning:**
To avoid any possibility of accidental suffocation, keep children away from the device and do not wrap hose or cable around the neck.
25. **Warning:**

Correct Disposal of This Product

(Waste Electrical & Electronic Equipment)



This marking shown on the product indicates that it should not be disposed with other household waste at the end of its life. To prevent potential harm to the environment or to human health, please separate this product from other types of wastes and recycle it responsibly. When disposing this type of product, contact the retailer where product was purchased or contact your local government office for details regarding how this item can be disposed in an environmentally safe recycling center. Business users should contact their supplier and check the terms and conditions of the purchasing agreement. This product should not be mixed with other commercial wastes for disposal. This product is free of hazardous materials.